



Best Quality Best Safety

Zhengzhou Risever Industry Co.,Ltd

Add: No.24 Luyuan Road Huiji District,Zhengzhou,Henan Province,China

www.risever-industry.com

Tel:008615037233023

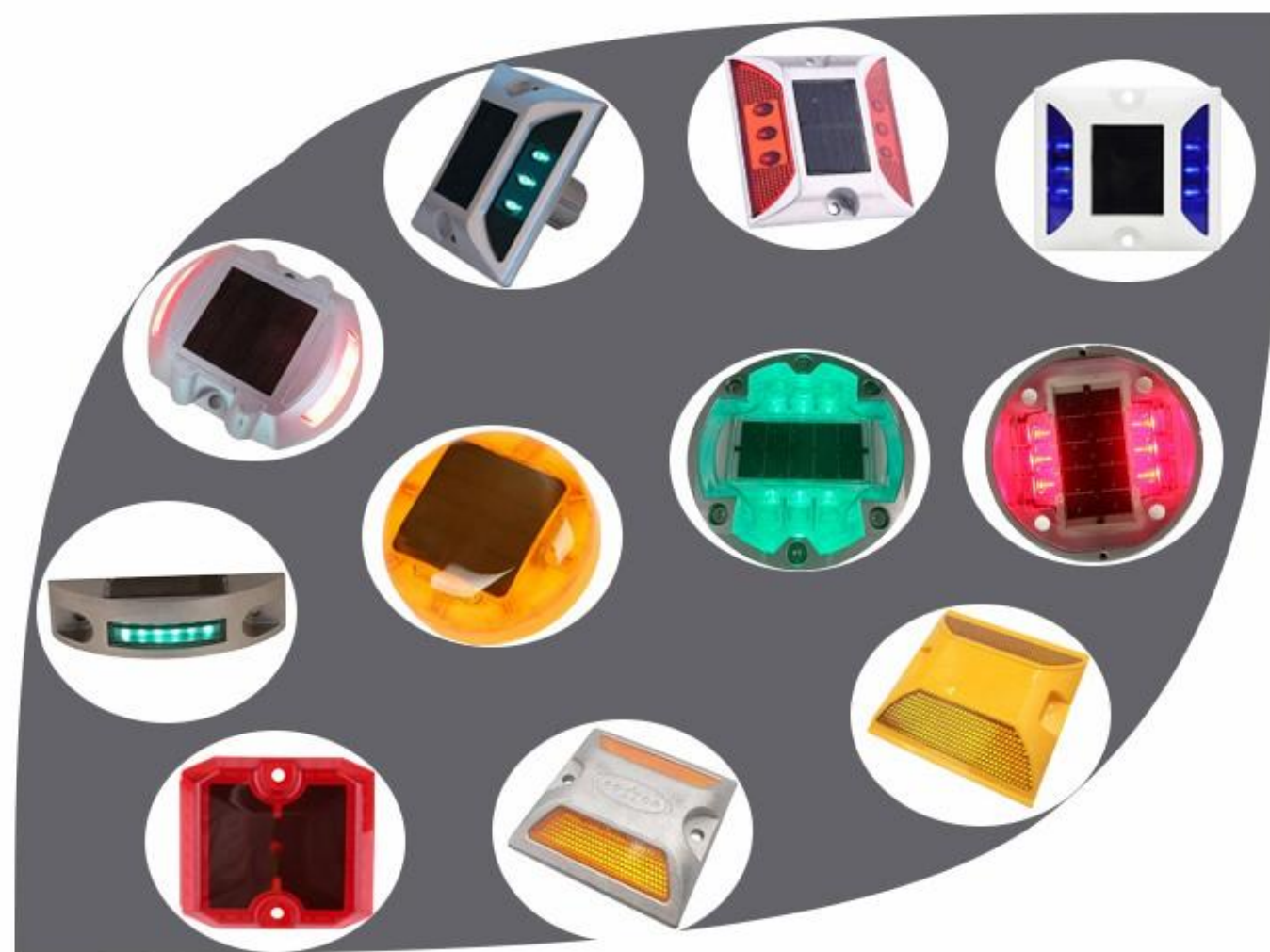

Email: info@risever-industry.com

Web: www.risever-industry.com

Whatsapp: 008615037233023

Contact: Chris Zhang



www.risever-industry.com

Tel:008615037233023

Company Profile

Zhengzhou Risever Industry Co.,Ltd was set in 2008, which is a comprehensive enterprise engages in producing, R&D and solving problems of various traffic safety products.

Zhengzhou Risever equipped with debugging and system integration of professional dust-free production workshop 3000 square meters, it has a strict and perfect fine management system in parts, production and quality control, which provides a reliable guarantee for the delivery cycle, quality control and high pass rate.

We are deeply engaged in the industry, keep the pulse of the industry, and adhere to the guidance of "quality, integrity, safety and energy saving". Adhere to the strategy of product R&D, manufacturing and sales. Up to now, the products have been exported to Southeast Asia, Europe and America, the Middle East and Australia, Africa, South America and other hundreds of countries and regions.

We focus on the production and sales of road safety industry for 15 years. In addition to solar road studs and reflective road studs, we also provide road facilities such as traffic lights and sign warning lights. If you want to know more, please contact us and we will get back to you as soon as possible within 24 hours reply.



www.risever-industry.com

Tel:008615037233023

Company Profile



CE



RoHS



IP68



FCC



ErP



ETL

www.risever-industry.com

Tel:008615037233023

→ Factory View



www.risever-industry.com

Tel:008615037233023

3

→ Factory View



www.risever-industry.com

Tel:008615037233023

4



www.risever-industry.com

Tel:008615037233023

5

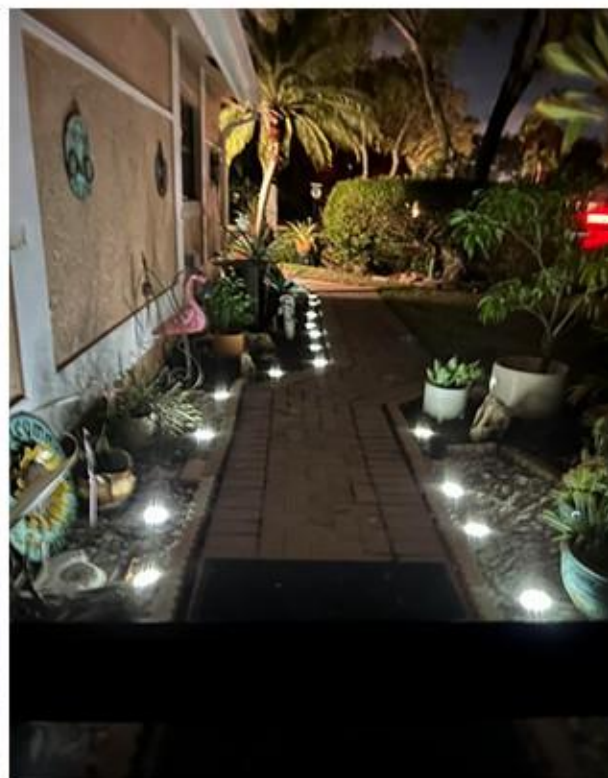

www.risever-industry.com

Tel:008615037233023

6

→ RSV-B101/B102 Photos and Design Drawing

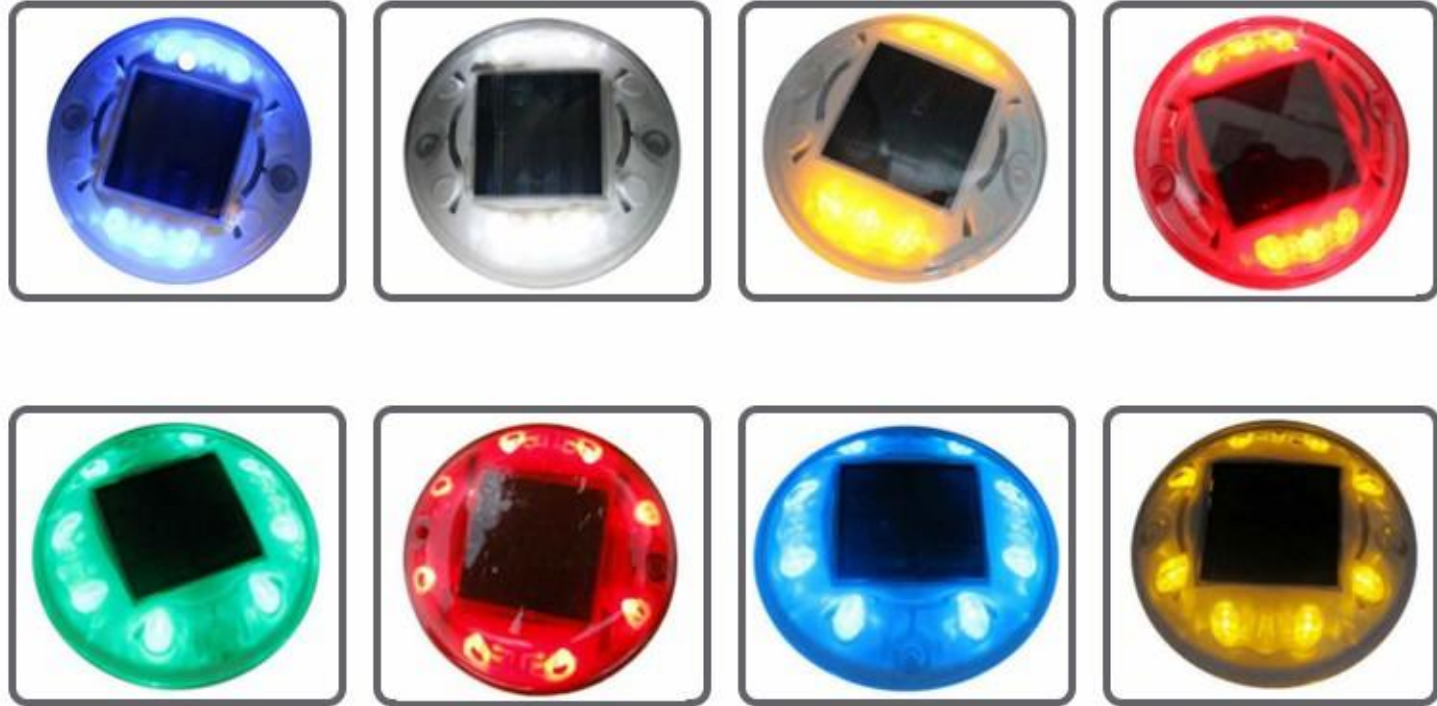

→ Project



Model No.	Material	Size	Solar Panel	Battery	LED Qty	LED Color	Work Mode
RSV-B101	Anti-UV PC	Φ 115 H=23 (mm)	2V/100mA	1.2V/600mAH	3,6,8,10 for choice	Red, Yellow	Flash or Steady
RSV-B102		Φ 120 H=23 (mm)	2V/200mA	1.2V/1200mAH		Blue	
			Monocry stalline	NI-MH Battery		Green, Blue	

→ RSV-B103 Photos and Design Drawing



→ RSV-B104 Photos and Design Drawing

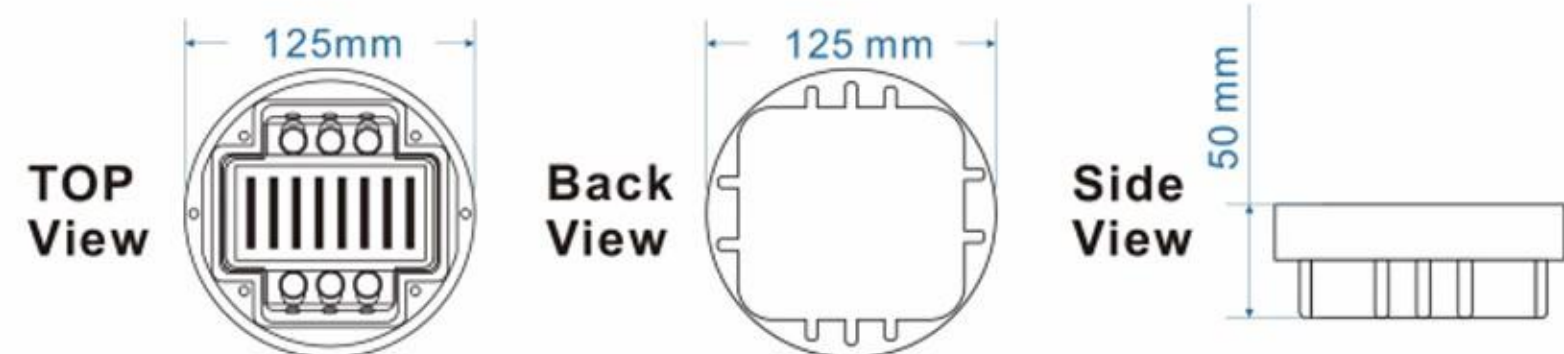

RISEVER Solar Road Stud

RSV-A105/A106 Photos and Design Drawing



Model No.	Material	Size	Solar Panel	Battery	LED Qty	LED Color	Work Mode
RSV-A105	Aluminium	115*110*23	2V/100mA	1.2V/600mAH	4,6	Red, Yellow	Flash or Steady
RSV-A106	+Anti-UV PC	mm	Monocry stalline	NiMH Battery	for choice	Blue Green, Blue	



RISEVER Solar Road Stud

RSV-GB114 Photos



RSV-GB115 Photos



RSV-WB112 Photos



RSV-WB113 Photos



→ **RSV-B105 Photos and Design Drawing**

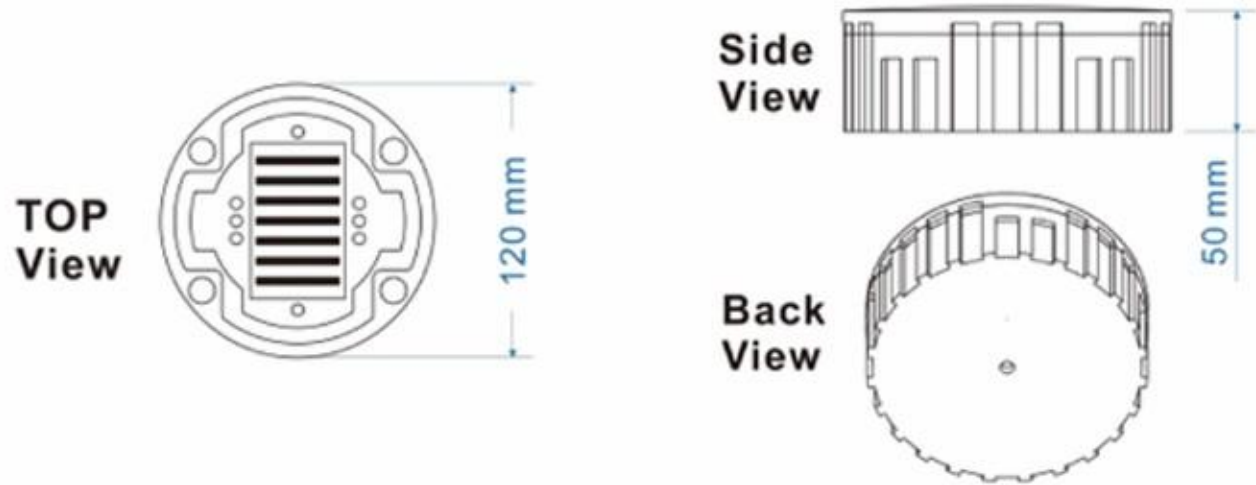

www.risever-industry.com

→ **RSV-B110 Photos and Design Drawing**

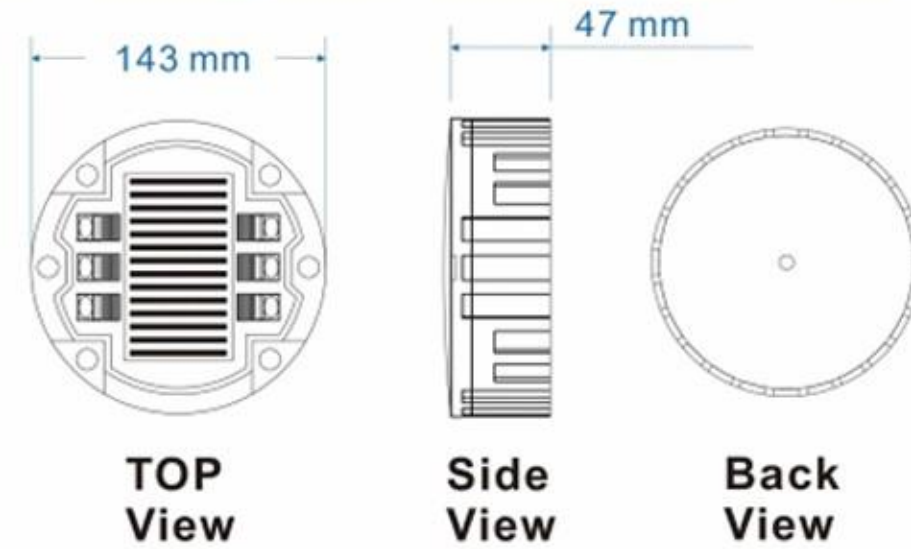

Tel:008615037233023

→ **RSV-A101/A102 Photos and Design Drawing**

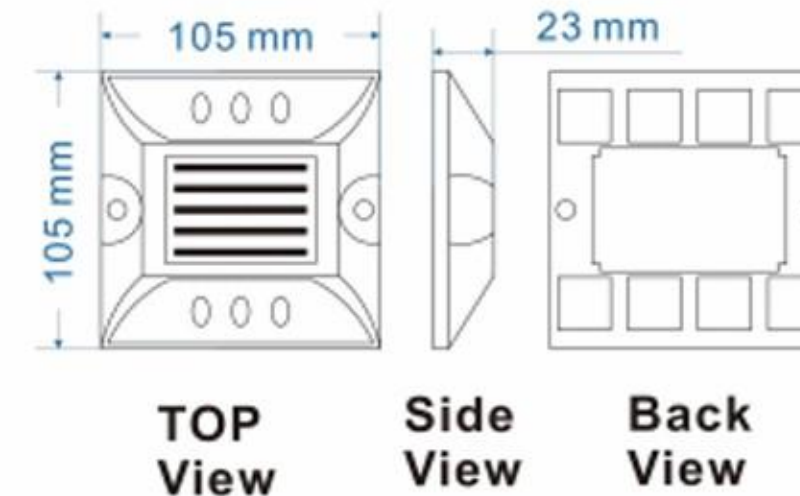
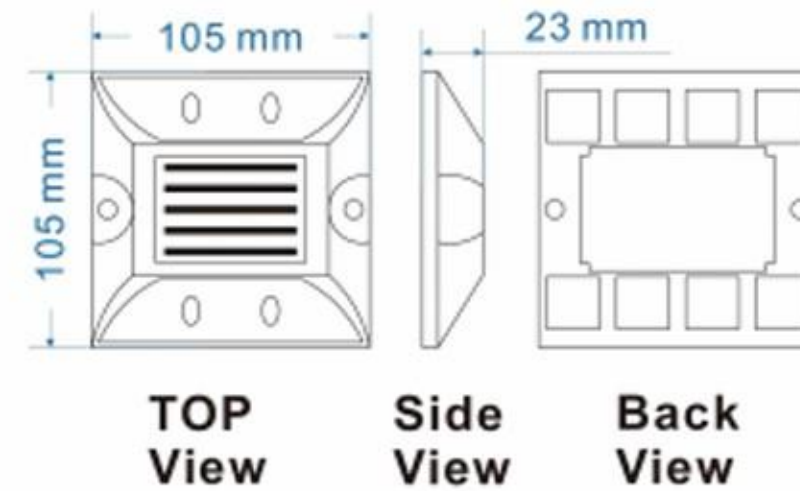

Model No.	Material	Solar Panel	Battery	LED Qty
RSV-A101	Anti-UV PC	2V/100mA	1.2V/600mAH	2,4
RSV-A102	+Aluminum	Monocry stalline	NI-MH Battery	or 3,6

www.risever-industry.com

Tel:008615037233023

→ RSV-A103 Photos and Design Drawing



RSV-A103

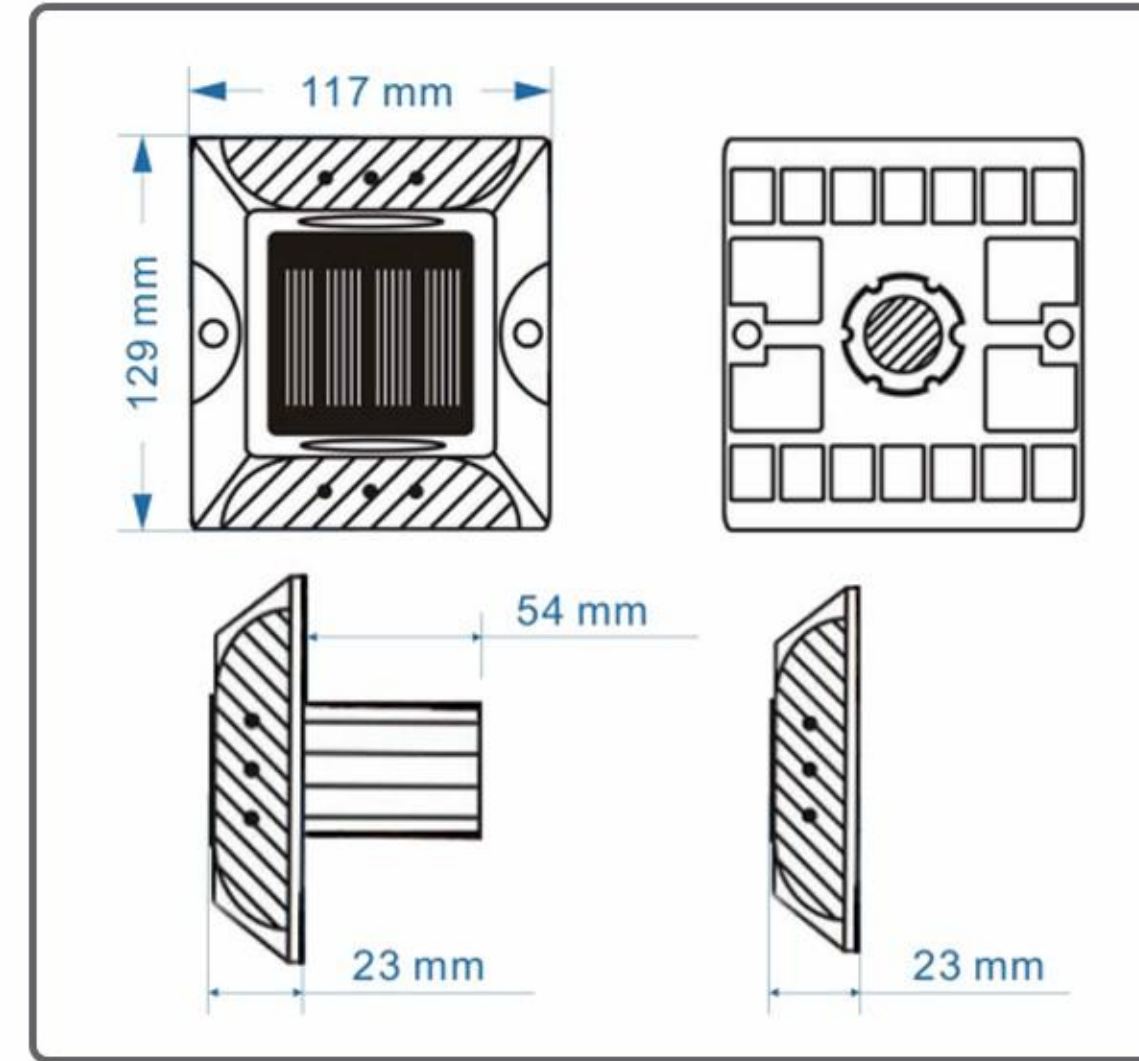

Tel:008615037233023

www.risever-industry.com

→ RSV-A104 Photos and Design Drawing



RSV-A104

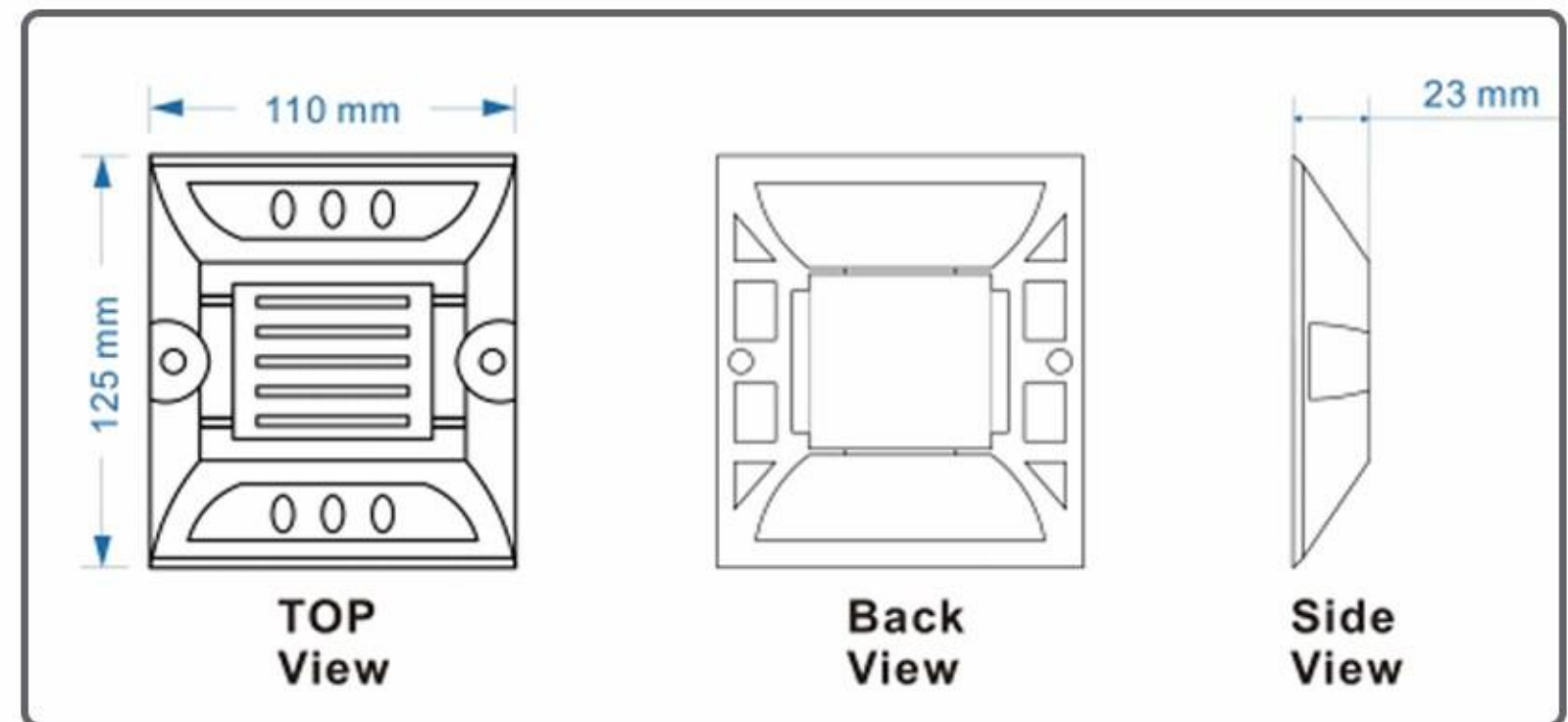

Tel:008615037233023

www.risever-industry.com

→ **RSV-C101 Photos and Design Drawing**



Model No.	Material	Size	Solar Panel	Battery	LED Qty	LED Color	Work Mode
RSV-C101	Anti-UV PC +Aluminum	110*95*23mm	2V/200mA Monocrystalline	1.2V/600mAH NI-MH Battery	3,6 for choice	Red, Yellow Blue Green, Blue	Flash or Steady



www.risever-industry.com

→ **RSV-C102 Photos and Design Drawing**

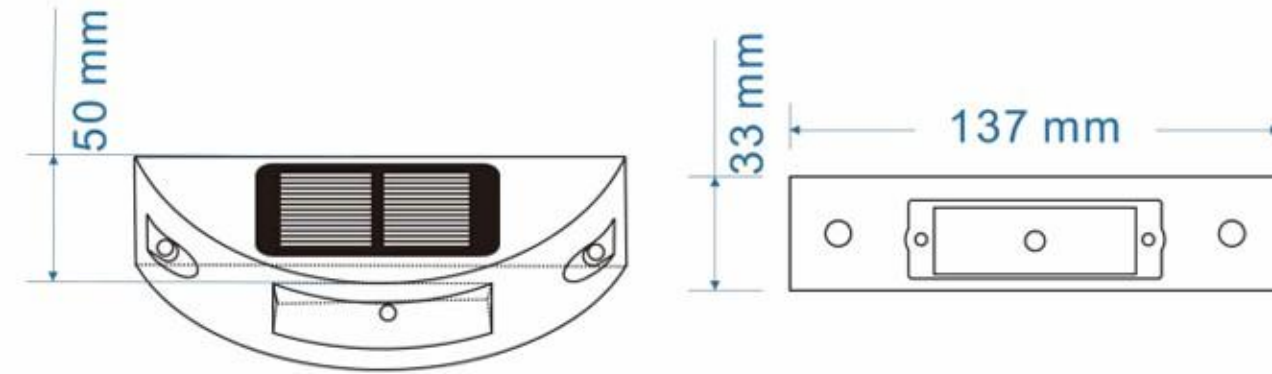

Tel:008615037233023

→ **RSV-C103 Photos and Design Drawing**

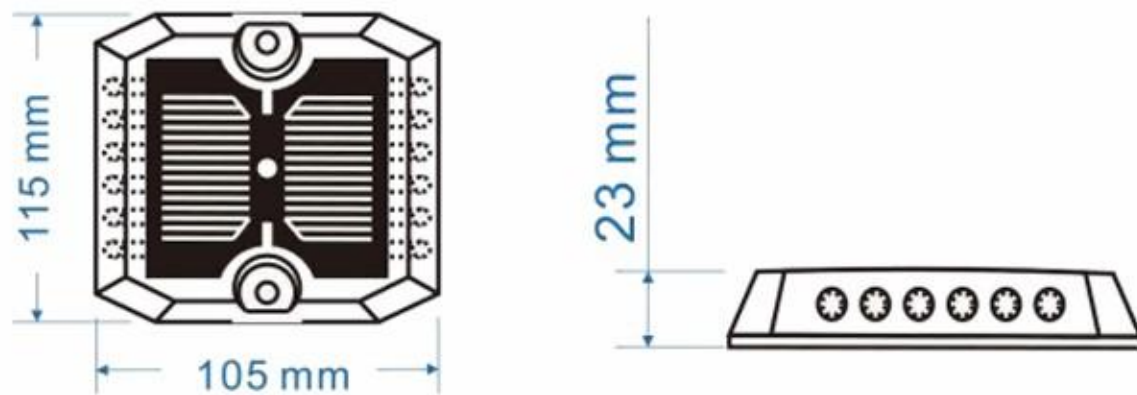
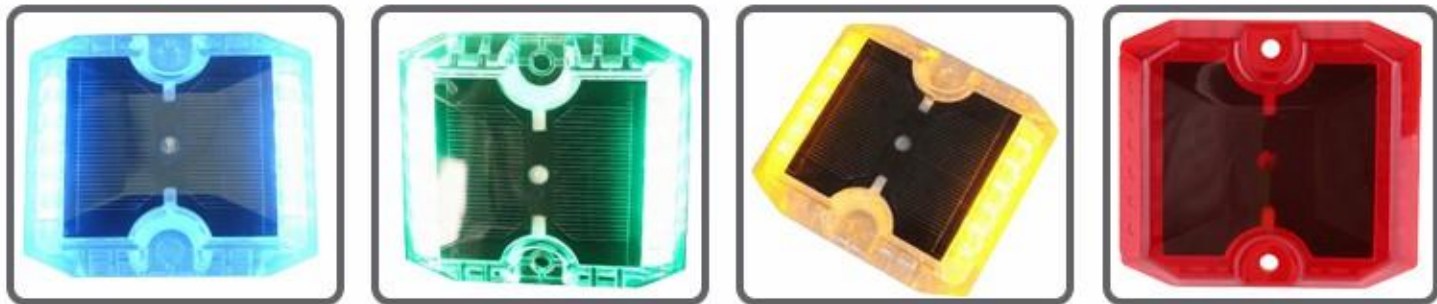

www.risever-industry.com

→ **RSV-D101/D102 Plastic Reflective Road Stud Photos**



→ **RSV-E101 Aluminium Reflective Road Stud**



Tel:008615037233023

→ **RSV-F101 Moveable Solar Traffic Signal**



Model Number	RSV-F101
Solar Panel	160W/18V Monocrystalline
Battery	12V/160AH(A) Lead Acid Battery
Protect Level	IP65
Flashing Mode	50times/minute or Customized
Pattern	24h or light controlled
Visual Distance	> 800m
Working Time	> 100hours after full charging
Light Area	300mm
Material	Metal with Coating and Aluminium Visor
Lifespan	> 3years

www.risever-industry.com

→ **RSV-G101 Solar Blinking Warning Light**



Model Number	RSV-G101
Solar Panel	6W/18V Monocrystalline
Battery	12V/7AH Lead Acid Battery
Protect Level	IP55
Size	530*170*135mm
Visual Distance	> 800m
The Diameter of Base Pole	Diameter 80mm
Working Time	> 200hours after full charging
Material	Anti-UV PC and Aluminium
Wind Resistance	≥1.5KN/m ²
Lifespan	> 3years

Tel:008615037233023

17

→ **RSV-G103 Sprinkler Arrow Light**



Model Number	RSV-G103
Protect level	IP55
Flashing Mode	Left,Right,All Flashing or Off
Visual Distance	> 800m
Control Mode	Manual Button Control
Intensity	4000-5000mcd
LED Color	Yellow
Work Temperature	-20 °C to +80 °C
Size	600*275*100mm
Power	38W

www.risever-industry.com

→ **RSV-G102 Solar Yellow Flashing Warning**



Model Number	RSV-G102
Solar Panel	8W/18V Monocrystalline
Battery	12V/7AH(A) Lead Acid Battery
Protect Level	IP55
Flashing Mode	50times/minute or Customized
Pattern	24h or light controlled
Visual Distance	> 800m
Working Time	> 200hours after full charging
LED Color	Yellow
Material	Anti-UV PC and Aluminium

Tel:008615037233023

18

→ **RSV-H101 Solar Pedestrian Sign**



Model Number	RSV-H101
Solar Panel	3W/12V Monocrystalline
Battery	7.4V/5AH(A) Lithium Battery
Protect Level	IP55
Flashing Mode	Flashed
Visual Distance	> 800m
Working Time	> 200hours after full charging
LED Color	Yellow, White or Customize
Material	Aluminium+3M Reflecting Film
Size	600*600*65mm

www.risever-industry.com

→ **RSV-H102 Solar Stop Sign**

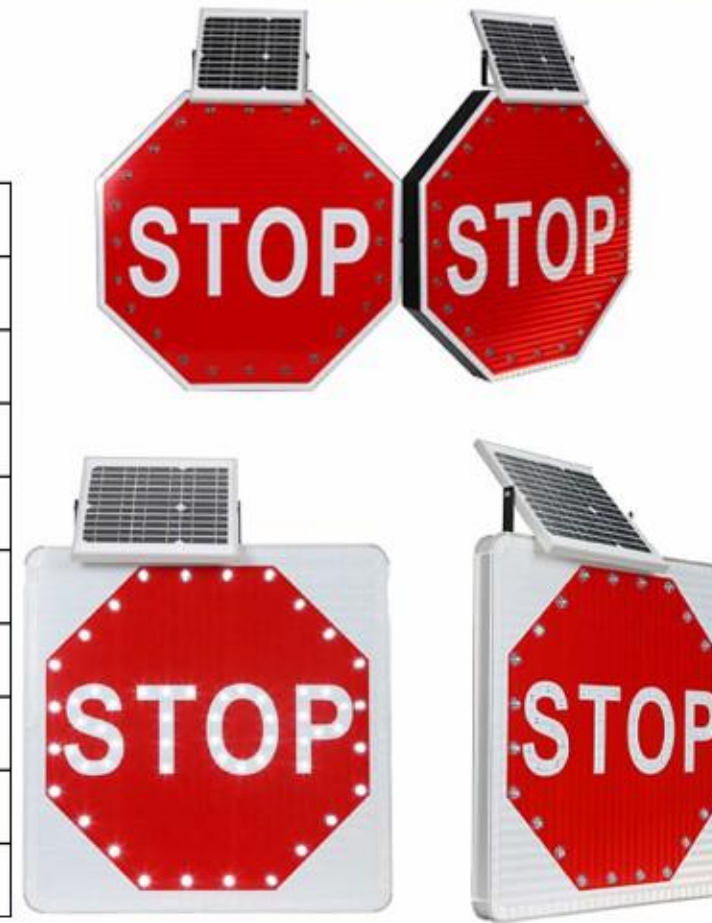

Model Number	RSV-H102
Solar Panel	3W/12V Monocrystalline
Battery	7.4V/5AH(A) Lithium Battery
Protect Level	IP55
Flashing Mode	Flashed
Visual Distance	> 800m
Working Time	> 200hours after full charging
LED Color	Yellow, White or Customize
Material	Aluminium+3M Reflecting Film
Size	600*600*65mm

Tel:008615037233023

→ **Application**



www.risever-industry.com

Tel:008615037233023